

Water and Wastewater Minimization in Tehran Oil Refinery using Water Pinch Analysis

Nabi Bidhendi, Gh. R., Mehrdadi, N. and Mohammadnejad, S.*

Graduate Faculty of Environment, University of Tehran, P.O. Box: 14155-6135, Tehran, Iran

Received 12 March 2009;

Revised 17 June 2010;

Accepted 25 June 2010

ABSTRACT: This study aimed to find an appropriate way to minimize water utility in the petrochemical and petroleum industries. For this purpose, Tehran oil refinery was chosen to analyze feasibilities of regeneration, reuse and recycling in the water network. In this research, two key contaminants including COD and hardness were analyzed. Amount of freshwater was reduced about 180 m³/h (53%) and 216.88 m³/h (63%) regarding COD and hardness respectively. In the next stage, two mentioned contaminants were analyzed simultaneously based on the mass transfer constraints. Results showed that the amount of required water was reduced from 340 m³/h to 197.12 m³/h that was about 42%. Analyzing both methods clearly demonstrated that amount of required water would be determined by mass transfer of COD. In addition, the method based on multiple contaminants gave more precise results rather than single contaminant.

Key words: Water utility, Water reuse, Minimization, Mass transfer, Regeneration

INTRODUCTION

Generally, water is used as raw material in most of the industries and generated wastewater is discharged in to the environment. Increasing freshwater utility is due to economical and industrial growth, considerably (Rajakumar and Meenambal, 2008; Rajasimman and Karthikeyan, 2009; Yoochatchaval *et al.*, 2008; Biati *et al.*, 2010; Aminzadeh *et al.*, 2010; Bagherzadeh-Namazi *et al.*, 2008; Mehrdadi *et al.*, 2007; Abduli *et al.*, 2007; Dabhade *et al.*, 2009). On the one hand, the price of water is increased which consequently raises the price of products. On the other hand, the environmental laws do not allow discharging wastewater in to the environment. (Karbassi, *et al.*, 2008; Praveena, *et al.*, 2010; Vargas-Vargas, *et al.*, 2010; Biati, *et al.*, 2010). Therefore, industries have to use some strategies related to water utility minimization. Industrial wastewater management through different methods has been taken into consideration during recent years in Iran (Ataei and Yoo, 2010; Saeedi and Amini, 2007; Sarparastzadeh *et al.*, 2007; Nabi Bidhendi *et al.*, 2007; Hassani *et al.*, 2008; Amini *et al.*, 2008; Kabir and Ogbeide, 2008; Hassani *et al.*, 2009; Moayed Salehi and Mirbagheri, 2010). Nowadays, different techniques and methods have been developed to design water allocation system so that water utility is reduced in an acceptable level. Water pinch technology is a systematic technique for analyzing water networks and reducing expenditures related to different water using processes (Manan, *et al.*, 2006; Hallale, *et al.*, 2001;

Ataei, *et al.*, 2010; Ahmed, *et al.*, 2009 and Gomez, *et al.*, 2006; Omran *et al.*, 2009; Khezri *et al.*, 2010). El-Halwagi (1992) propounded the theory of mass exchange networks. This theory was based on a two-stage solution; first, Mixed Integer Nonlinear Programming and then Mixed Integer Linear Programming. Most of the methods used in water pinch analysis are based on the mass exchange of one or several contaminants (Ataei and Panjehshahi, 2009). If the mass exchange is based on mass transferring of one contaminant, the problem will be solved as a single contaminant. Nevertheless, if it includes mass transferring of two or more key contaminants, the problem will be solved as multiple contaminants. Graphical, mathematical and computer-based methods may be used for both cases. Each method has some advantages and disadvantages. Graphical methods are so practical to solve single contaminant problems. However, they are complicated and sometime impossible for multiple contaminants problems. (Alizadeh, *et al.*, 2010; Bhatnagar, *et al.*, 2009; Hassani, *et al.*, 2009). Wang and Smith (1994) used limiting composite curve to solve multiple contaminants problems. Kuo and Smith (1997) applied a new method to reduce complexity of graphical method based on breaking the operations. Majozi, *et al.* (2005) Presented a graphical technique for freshwater and wastewater minimization in completely batch operations. Water minimization was achieved through the exploitation of inter- and intra-process water reuses and recycles

*Corresponding author E-mail: mohammadnejads@gmail.com

opportunities. In addition, Foo, *et al.* (2005) presented a two-stage procedure for the synthesis of a maximum water recovery (MWR) network for a batch process system, covering both mass transfer-based and non-mass transfer-based water-using processes. Mathematical methods are more exact but sometime complicated especially in the case of multiple contaminants (Ataei, *et al.*, 2009). There is different computer programming for users such as GAMS programming. Gomez (2006) used a water source diagram method based on outlet flow-rate. Alva-Argaez, *et al.* (2007) introduced a systematic methodology that empowers conceptual engineering and water-pinch with mathematical programming methods. The method focuses on petroleum refineries explaining trade-offs and savings between freshwater costs, wastewater treatment, piping costs and environmental constraints on the discharge. Gouws, *et al.* (2008) used a mathematical technique for water minimization in multipurpose batch processes. Oliver, *et al.* (2008) used water pinch analysis and mix integer linear programming (MILP) to synthesize the water network for batch processes. Mohammad Nejad, *et al.* (2010) studied the optimization of water and steam allocation network based on mathematical methods. Consequently, they developed an algorithm to simplify the relevant calculations and applied it for reforming the network in a petroleum refinery. In this research, two key contaminants including hardness (H) and COD have been considered to analyze the feasibilities of regeneration reuse and regeneration recycling in the water network for water and wastewater minimization. Besides, this research is based on the work of Wang and Smith in 1994. Two mentioned key contaminants once were analyzed separately as a single contaminant and the amount of required fresh water was calculated for both of them, so in which case that water minimization is less than another one, it could be selected as a limiting contaminant for processes. This method can be applied easily for different industries and mathematical calculations are not complicated as well. After that, two mentioned contaminants were analyzed simultaneously based on their mass transfer. In other words, mass transfer of a contaminant was analyzed with respect to another one. Firstly, limiting water profile is drawn based on inlet and outlet concentrations of one of the contaminants then the concentration of second one is calculated in each concentration interval. Here, fraction θ_{in} is defined as a ratio of the actual flow-rate to operation i at concentration interval boundary n to the limiting flow-rate of operation i . This fraction is used to design the water network and according to this, total flow-rate of network is obtained. Finally, the results of two methods are compared. In this study, regeneration reuse and

regeneration recycling processes have been placed in the water network. One of the current treatment processes in the refinery including American Petroleum Institute (API) has been chosen as a regeneration unit based on its Removal Ratio (RR) and operational expenditure. It is assumed that, only 80 % of treated wastewater from the regeneration unit may be reused or recycled into water using operations.

MATERIALS & METHODS

This research has been performed for Tehran oil refinery from 2006 to 2009. The studied refinery comprises two refineries and some petroleum processing manufactories. The simplified flowchart of water and steam allocation network in the refinery has been showed by Fig. 1. Currently this refinery utilizes about 505 m³/h water. As it is seen, water and steam allocation network in the refinery is well designed and amount of water utility and wastewater generation are in an acceptable level while wastewater is reused or regenerated. Table 1 illustrates flow-rate and stream constraints in the water network. Based on these constraints, limiting water flow-rates are determined for optional operations. Water flow-rate is needed to achieve mass transfer of contaminants required for water minimization. Contaminant selection depends on the industry and its water requirements (Najafpour, *et al.*, 2008; Salehi, *et al.*, 2010; Nakane, *et al.*, 2010). In addition, it is very important to select processes, which have high rate of water consumption. According to these considerations, COD and hardness (H) were selected as key contaminants and three processes, which use vast amount of water such as desalter, cooling towers as well as portable; plant and fire were selected to be analyzed. These operations use water about 340m³/h that includes 67.4% of total water utility in the refinery.

There are two targets for wastewater minimization by water pinch technology:

- 1- Wastewater minimization considering single contaminant approach
- 2- Wastewater minimization considering double contaminants approach

RESULTS & DISCUSSIONS

To minimize wastewater by Single contaminant approach, it is necessary to calculate minimum water flow-rate required to reduce the contaminant concentration to an acceptable level. Therefore, it must be taken some steps. The first step is providing limiting process data table. This table includes minimum inlet and outlet flow-rates, maximum inlet and outlet concentrations as well as transferred mass by processes. In this research, mass load is calculated independently before minimization based on current

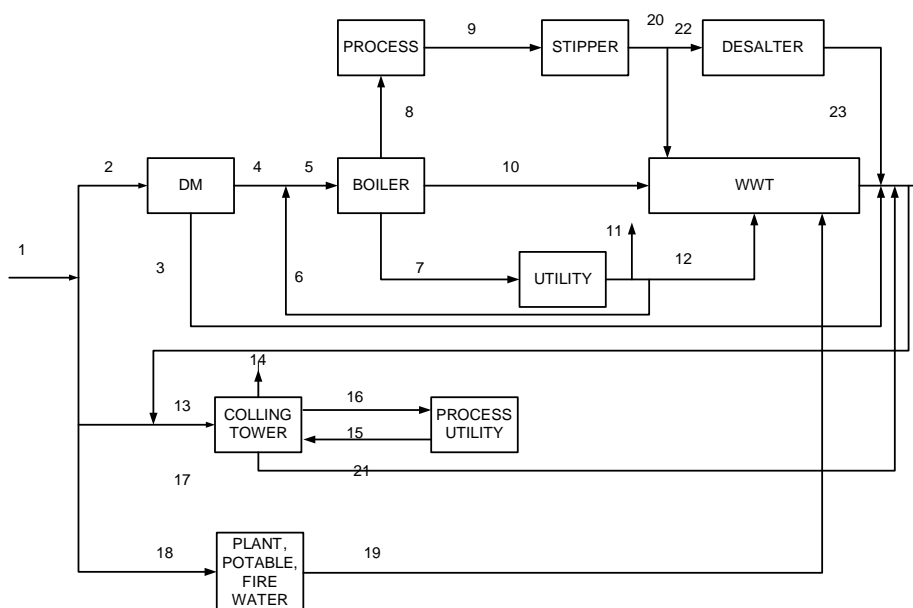

Fig. 1. Flowchart of water and steam allocation network in the refinery

Table 1. Flow-rates and stream constraints for the optional water network

No.	Flow rate(m ³ /h)	Stream constraints (ppm)
1	505	pH=7/9,T.COND.=360,T.H=150,COD=0 M-ALK=140,SiO ₂ =9/3,SS=1,TSS=2/15,T.Fe<0/05,Cl<0/05
10	20	pH=9/8,T.COND.=90,TH=0,T.Fe<0/05,PO ₄ =20,COD=0
13	113	pH=7/9,T.COND.=360,T.H=150, M- ALK.=140,SiO ₂ =9/3,S.S=1,T.SS=2/15,T.Fe<0/05,Cl<0/05,COD=0
15	37	PH=7/1,T.COND.=4350,T.H=1250, M-ALK.=30,SiO ₂ =48/9,S.S=1,T.SS=2/95,T.Fe=0/35,Cl=2/5
17	104	pH=7/6,T.COND.=1400,T.H=270, M-ALK.=66,SiO ₂ =9/87,S.S=2,T.SS=2/66,T.Fe<0/05,Cl<0/05
18	168	pH=7/9,T.COND.=360,T.H=150, M-ALK=140,SiO ₂ =9/3,SS=1,TSS=2/15,T.Fe<0/05,Cl<0/05,COD=0
19	160	PH=7/3,T.COND.=930,T.H=241,M-ALK=23,SS=22,COD=4
21	17	pH=5/5,T.COND.=850,TH=12,M- Alk.=44,SiO ₂ =6/6,SS=13,TSS=24/3,Tfe=0/83,Cl<0/05,H ₂ S=3/4,NH ₃ =46,COD=10
22	59	pH=5/5,T.COND.=850,TH=12,M- Alk.=44,SiO ₂ =6/6,SS=13,TSS=24/3,Tfe=0/83,Cl<0/05,H ₂ S=3/4,NH ₃ =46,COD=2
23	59	pH=6.5,T.COND.=1600,TH=160,M- Alk.=40,SiO ₂ =1.4,SS=20,TSS=25,Tfe=3.12,Cl<0.05,COD=5

Table 2. Limiting data for COD [single contaminant approach]

Operations i	Q _{in} (m ³ /h)	Q _{out} (m ³ /h)	C _{in} (ppm)	C _{out} (ppm)	Δm (kg/h)	Cumulative Δm (kg/h)
Cooling Tower	37	37	1	4	0.48	0.48
Desalter	59	59	2	5	0.1	0.58
Potable, fire, Plant water	160	160	3	10	0.2	0.78

Table 3. Limiting data for hardness [single contaminant approach]

Operations i	Q _{in} (m ³ /h)	Q _{out} (m ³ /h)	C _{in} (ppm)	C _{out} (ppm)	Δm (kg/h)	Cumulative Δm (kg/h)
Cooling Tower	37	37	150	1250	40.7	65.4
Desalter	59	59	12	160	8.732	8.732
Potable, fire, Plant water	160	160	400	500	16	24.7

Table 4. The constraints of operations for regeneration in terms of COD

Process	Inlet concentration for regeneration(ppm)	Flow-rate (m3/h)	Maximum environmental concentration
Desalter	5	59	1
Potable, fire, Plant water	4	37	1
Cooling Tower	10	160	1

Table 5. The constraints of operations for regeneration in terms of hardness

Process	Inlet concentration for regeneration(ppm)	Flow-rate (m3/h)	Maximum environmental concentration
Desalter	160	59	-
Potable, fire, Plant water	500	37	450
Cooling Tower	1250	160	450

maximum flow-rate in the network. Tables 2 and 3 show the limiting process data for the processes in terms of COD and hardness, respectively. Mass load calculate as follows:

$$\Delta m_{opi} = \frac{(C_{out} - C_{in})f_{opi}}{1000} \quad (1)$$

Since operations 1 and 3 lose freshwater, which is discharged as wastewater, it is necessary to separate water losses from utilized water within processes. After that, maximum environmental concentration is considered for each contaminant and each operation. (Tables 4 and 5)

In the next step, pinch point of operations is determined as some operations with the concentration lower than freshwater are supplied, but reach operations do not need freshwater. The minimum freshwater flow-rate is called water pinch. The pinch point is important to minimize wastewater because the system does not require freshwater above this point.

In this research, a graphical method named concentration composite curve has been used to determine pinch point (Mohammadnejad, *et al.*, 2010). Fig. 2 (a & b) represent the concentration composite curves for

outlet streams from regeneration unit in terms of COD and hardness respectively. According to these curves, horizontal and vertical axes show the mass load and the contaminant concentration respectively. In addition, the intersection of average treatment line and horizontal axis on the graph marks O which shows limiting treatment point. In other words, this point is the mass load of contaminant in the negative part of horizontal axis and used for calculation of minimum treatment flow-rate. On the other hand, the average treatment line crosses the composite curve in the pinch point. Fig. 3 (a and b) shows the concentration composite curve and water supply line for COD and h respectively. Clearly, the outlet streams enter the regeneration unit in the pinch point and having regenerated, they are reused or recycled in to operations. Minimum treatment flow-rate is calculated according to bellow equations:

$$r^i = \frac{\Delta m_{tot}}{m_o^i - \Delta m_{tot}} \quad (2)$$

$$f_{min}^i = \frac{\Delta m_{tot} + m_o^i}{c_{pinch}} \times 10^3 \quad (3)$$

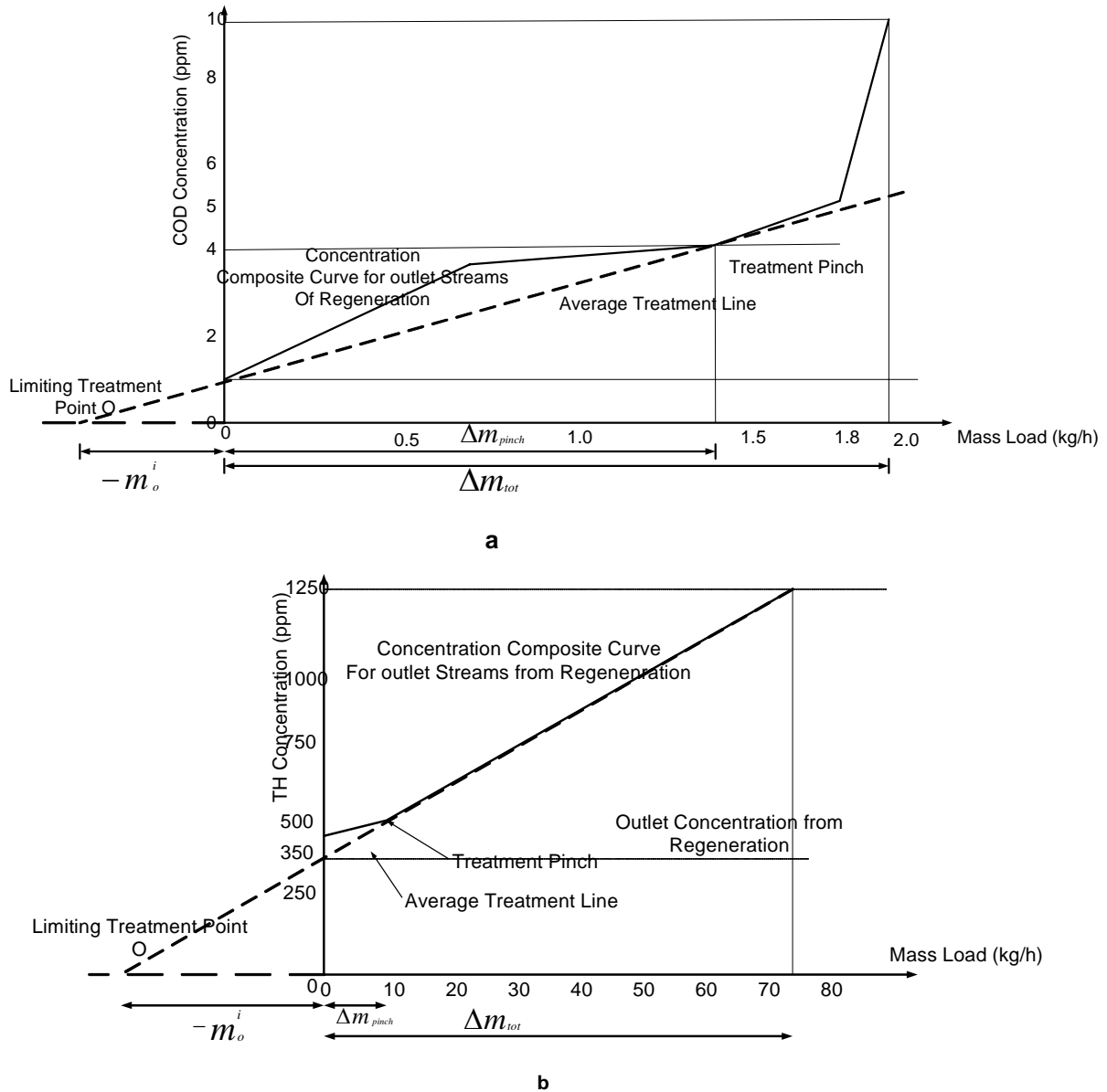

Fig. 2. The concentration composite curves for outlet streams of regeneration unit for COD(a) and hardness(b)

Here, r^i is removal ratio of the contaminant and Δm_{tot} is total concentration mass load (kg/h). The removal ratio for COD and hardness is 0.75 and 0.3 respectively. According to above-mentioned equations, the amount of minimum flow-rate for COD and H will be $1.55\text{m}^3/\text{h}$ and $20.6\text{m}^3/\text{h}$.

Wang and Smith's method is so easy and efficient for designing networks with minimum freshwater requirement in the different industries. In this method, at first concentration interval boundaries are selected from limiting process data tables for all operations. These interval boundaries are drawn as horizontal lines and different operations are drawn as upward-directed

arrows and water streams as downward-directed arrows. In this research, three water stream sources are considered including freshwater, boiler blow down and outlet utility. Transferred mass load of contaminant for each interval boundary is calculated as follows:

$$m_{i,k} \text{ (kg / h)} = \Delta m_{i,tot} \text{ (kg / h)} \left[\frac{C_{k+1}^* - C_k^*}{C_{i,out}^{lim} - C_{i,n}^{lim}} \right] \quad (4)$$

Then required water flow-rate is calculated for each transferred mass load according to below equation:

$$f_{i,k}^{tot} \text{ (m}^3 \text{ / h)} = \frac{m_{i,k} \text{ (kg / h)}}{[C_{k+1}^* - C_{i,k}^w] \text{ ppm}} \times 10^3 \quad (5)$$

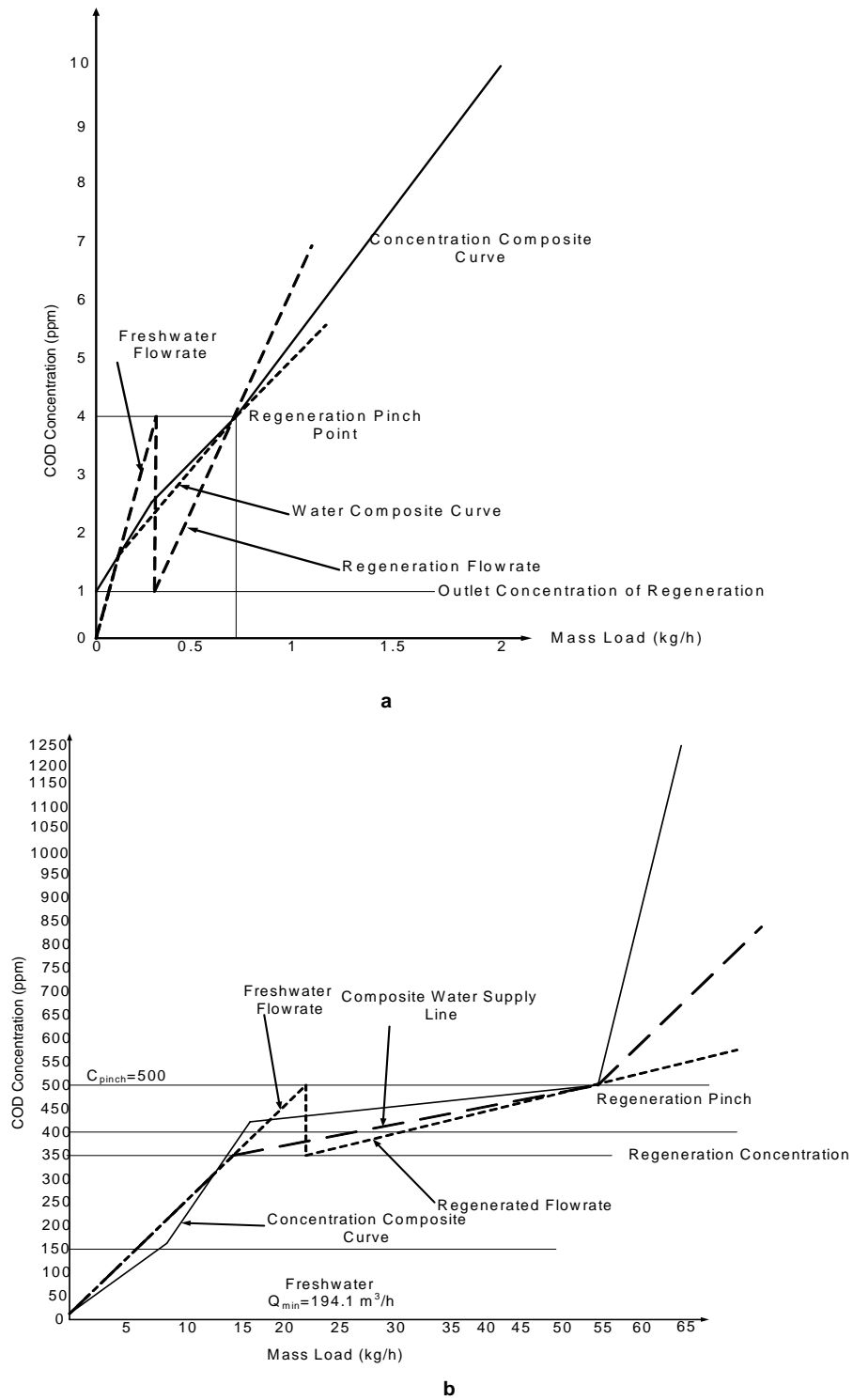
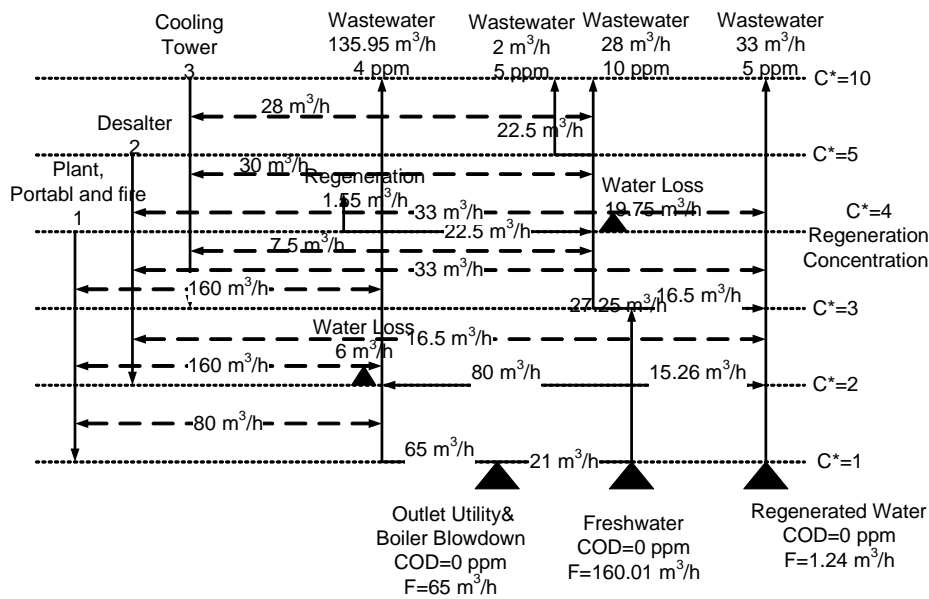

Fig. 3. The concentration composite curve and water supply line for (a) COD and (b) hardness

$f_{i,k}^{tot}$ is required flow-rate for each interval boundary and $C_{i,k}^w$ is average contaminant concentration of water stream for operation i entering interval boundary k .

Furthermore, the outlet streams with pinch concentration may enter regeneration unit then recycled to operation with the target 80% for recycling. Fig. 4 represents water network diagrams considering 80% recycling in terms of COD and hardness.



a

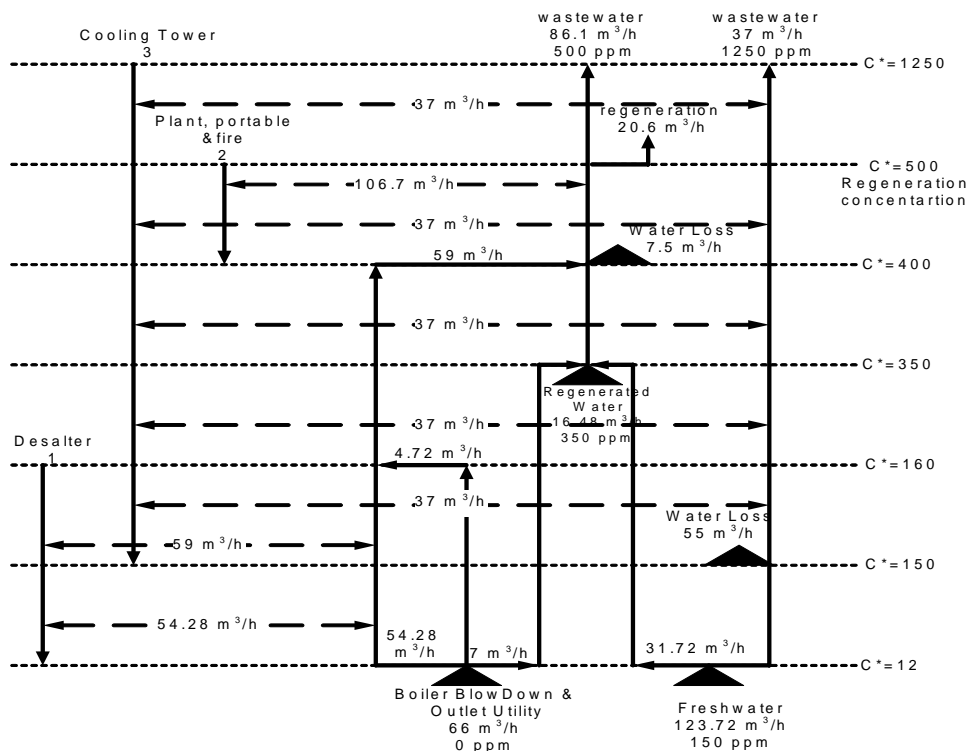

b

Fig. 4. Water network diagrams with placing 80% regeneration recycling for a) COD and b) hardness

Fig. 5 shows the final water network flowchart with placing regeneration unit in terms of COD and hardness. As it is clear, regarding COD, the outlet stream from portable, fire and plant operation enters regeneration unit then 80% of it is reused by desalter. For con-

taminant H, the outlet stream from portable, fire and plant operation enters regeneration unit then recycled to same operation considering 80% of recycling.

In Double contaminant approach, limiting water profile is drawn based on inlet and outlet concentration

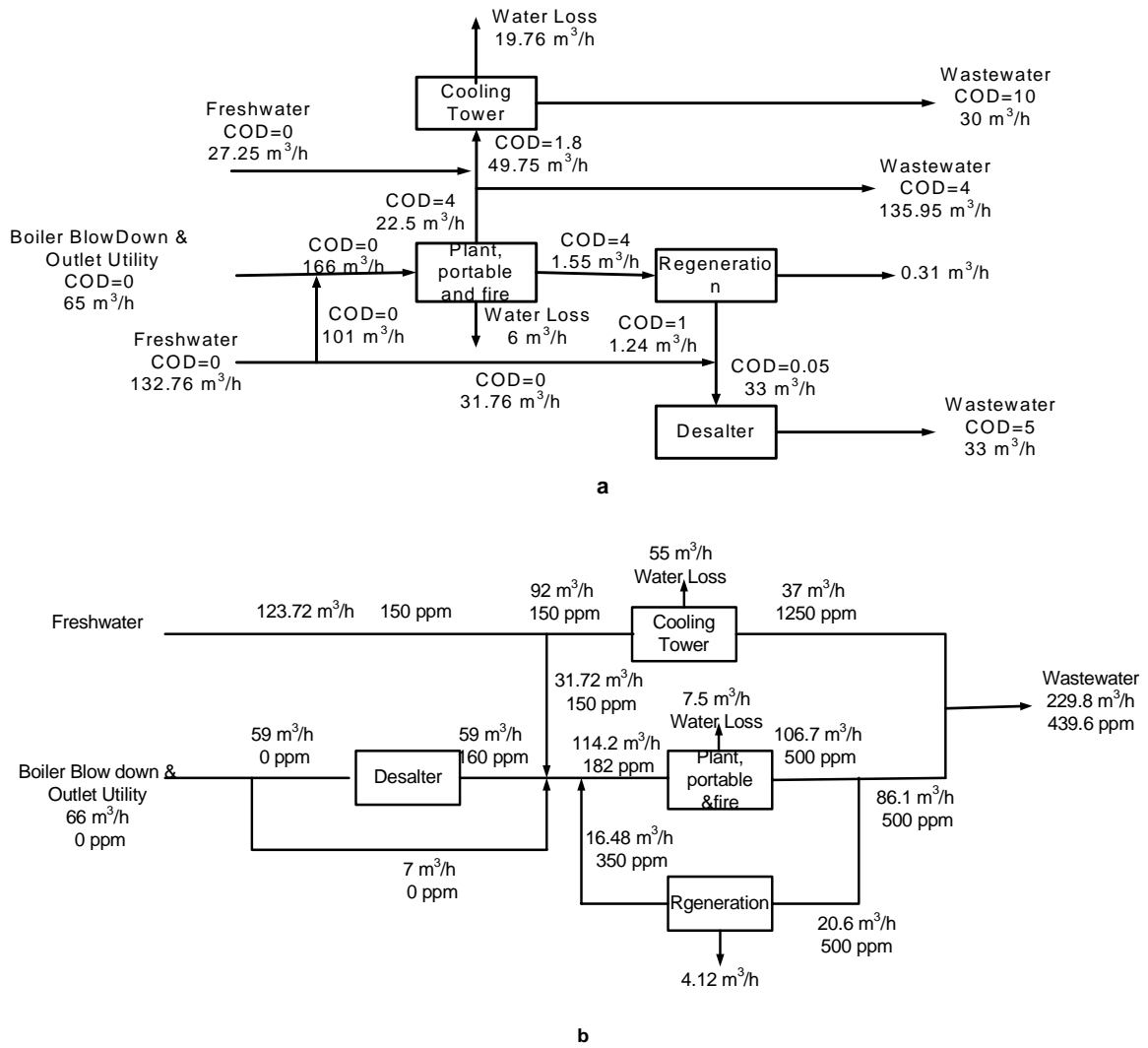

Fig. 5. Water network flowcharts with placing 80% regeneration recycling for a) COD and b) hardness

of one of the contaminants as a reference contaminant according to limiting process data shown in tables 2 and 3. Fig. 6 shows limiting water profile for three operations. In this profile, the concentrations of two key contaminants at each concentration interval boundary have been shown in the brackets for each operation. For example, [12, 2] means that, the concentration of reference contaminant and second one are 12ppm and 2ppm, respectively.

Then the concentration of second contaminant is calculated based on the first one by below equation:

$$\frac{C_{i,H,n} - C_{i,H,in}}{C_{i,H,out} - C_{i,H,in}} = \frac{C_{i,COD,n} - C_{i,COD,in}}{C_{i,COD,out} - C_{i,COD,in}} \quad (6)$$

After that, actual flow-rate is determined for operations based on ratio $\theta_{i,n}$.

$$f_{i,n} = f_i \times \theta_{i,n} \quad (7)$$

$f_{i,n}$ is actual flow-rate and f_i is inlet flow-rate. In addition, actual flow-rate can be calculated as follow:

$$f_{i,n} = T_{i,n} + q_{li,m \leq n} + F_{i,n} = f_i \times \theta_{i,n} \quad (8)$$

$T_{i,n}$ is water flow-rate available for reuse within operation i at interval boundary n. $q_{li,m \leq n}$ is water flow-rate from operation i at interval boundary n that is supplied by (or reused from) operation l at interval boundary m smaller than n and $F_{i,n}$ is required freshwater for each operation in each interval boundary. is obtained by following equation:

$$\theta_{i,n} = \max_j \left[\frac{C_{i,j,n+1} - C_{i,j,n}}{C_{i,j,n+1} - \overline{W}_{i,j,n}} \right] \quad (9)$$

is flow-rate weighted average concentration of the current water sources and is calculated as:

$$\bar{W}_{i,j,n} = \frac{T_{i,n} \times W_{i,j,n} + \sum_l q_{li,m \leq n} \times W_{lj,m \leq n}}{T_{i,n} + \sum_l q_{li,m \leq n} + F_{i,n}} \quad (10)$$

$$W_{i,j,n+1} = \bar{W}_{i,j,n} + \frac{f_i \times (C_{i,j,n+1} - C_{i,j,n})}{T_{i,n+1}} \quad (11)$$

$W_{i,j,n+1}$ is outlet concentration of each operation and inlet concentration of next one.

To design the water network, at first concentration interval boundaries are drawn. Then water flow-rate is calculated for each operation in each interval boundary based on mass transfer of key contaminants (COD and H) by above- mentioned equations.

For example, the water flow-rate for interval boundary 1 and operation 1 is calculated as follow:

1. Determining $\theta_{i,n}$

$$\theta_{1,1} = \max \left[\frac{150 - 12}{150 - 0}, \frac{19.5 - 13}{19.5 - 1} \right] = \max[0.92, 0.3] = 0.92$$

2. Calculating required flow-rate

$$f_{i,1} = 0.92 \times 59 = 54.28 m^3 / h$$

3. Calculating outlet concentration

$$W_{1,SS,2} = 1 + \frac{59 \times (19.5 - 13)}{54.28} = 8.1 ppm$$

$$W_{1,H,2} = 1 + \frac{59 \times (150 - 12)}{54.28} = 150 ppm$$

Likewise, water flow-rate and outlet concentration are calculated for the rest of the operations in each interval boundary.

Unfortunately, there is no reasonable rule for placing regeneration processes in a water network and drawing the diagrams as well. This research provides a method based on analysis of single contaminant consideration for regeneration placement (Mann and Liu, 1999). Accordingly, at first, the minimum treatment flow-rate is calculated for each contaminant by Eqs. 1 and 2.

After that, the greatest value is considered as a total minimum treatment flow-rate:

$$f_{\min} \left(\frac{m^3}{h} \right) = \max \{ f_{\min,SS}, f_{\min,H}, f_{\min,COD} \} \quad (12)$$

Therefore:

$$f_{\min,COD} \left(\frac{m^3}{h} \right) = 1.55$$

Although the minimum treatment flow-rate is 20.6m³/h, the regeneration unit could regenerate water more, so the whole outlet flow-rate from cooling tower is transferred into regeneration unit and regenerated into portable; plant and fire operation. Next step is selection of some streams for treatment. Minimum flow-rate is deducted from flow-rate of the most polluted stream and the rest is considered for other polluted streams. Therefore, the cleanest stream remains as a last alternative for treatment. In this method, contaminants are treated to get appropriate concentration for using by all processes. In this research, outlet regeneration concentration is determined based on the specification of regeneration unit, which could be an advantage compared to Mann and Liu 's method. In other words, outlet treatment concentration may not be usable for all processes, so this concentration is used by process, in which inlet contaminant concentration is equal or greater than outlet treatment concentration. Accordingly, although the maximum treatment flow-rate is considered for regeneration, it can be less, more or equal to actual flow-rate. Fig. 7 and 8 illustrate the final water network diagram and the final flowchart for three optional operations considering 80% regeneration recycling As it is seen, desalter does not require freshwater and just reuses water from outlet utility and boiler blow down. Potable, plant and firewater is supplied by water reuse from desalter. In Addition, the whole outlet flow-rate from cooling tower is transferred into regeneration unit. Table

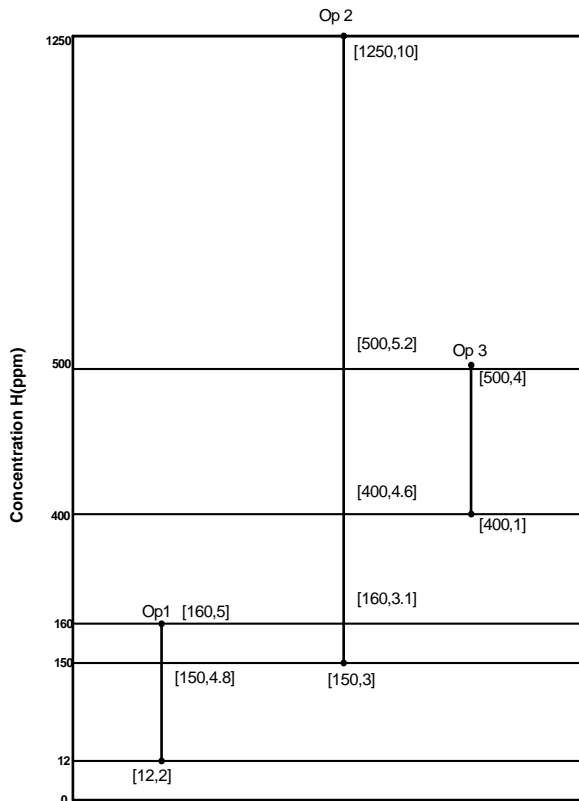

Fig. 6. Limiting water profile

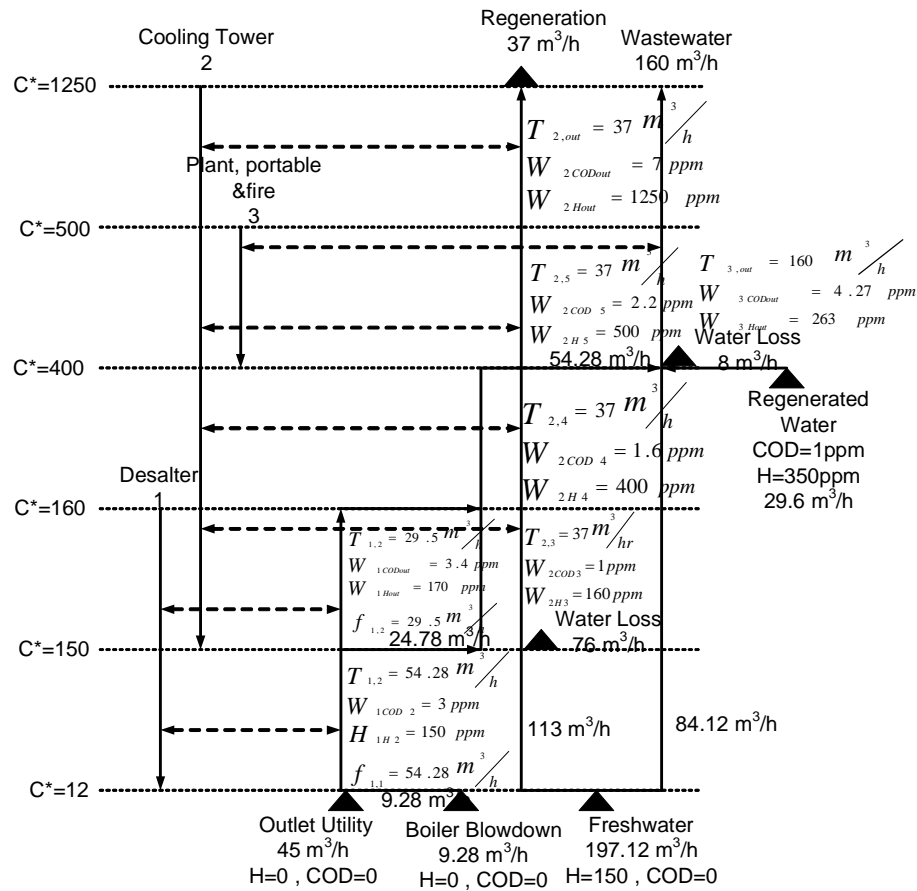

Fig. 7. Final water network diagram for 80% recycling

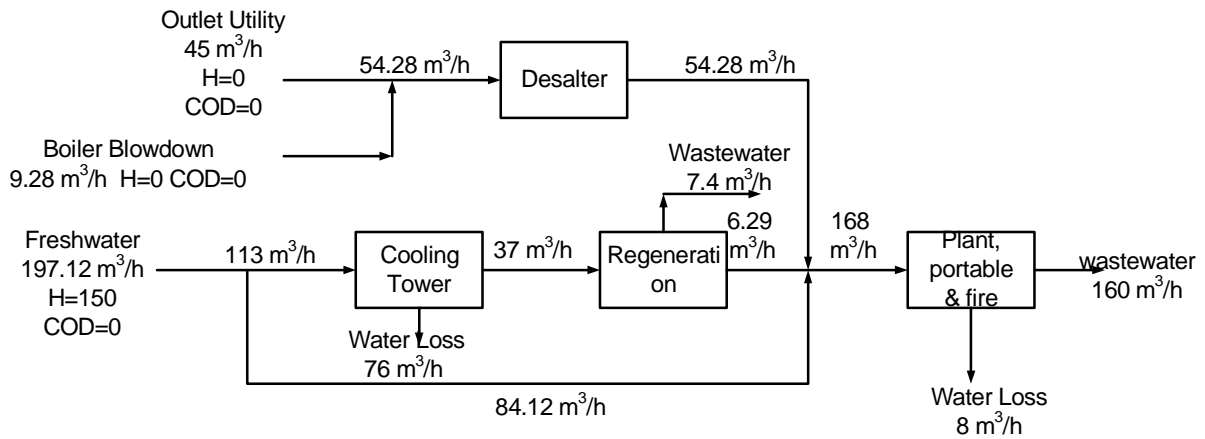

Fig. 8. Final water network flowchart for 80% recycling

Table 6. The summary of results for water minimization

Methods	contaminant	Required freshwater with regeneration recycling(m ³ /h)	Percentage of reduction (%)
Single contaminant approach	COD	160	53
	H	123.72	63
Double contaminant approach	COD&H	197.12	42

6 gives a summary of main results of water minimization from two studied methods. Clearly, in the single contaminant consideration, water minimization regarding COD is less in comparison with hardness. As a result, COD is a limiting contaminant and could be selected as a key contaminant. On the other hand, compared to double contaminant consideration, water minimization through single contaminant consideration is more considerable.

CONCLUSION

Nowadays, the crisis of water storage, discharging wastewater into the environment as well as expenditures of water supply and wastewater treatment are the main reasons for finding new methods to minimize freshwater utility in the different industries. Since water is intensively used in petrochemical and allied industries especially petroleum refineries, water pinch technique is introduced as an efficient method to minimize water and wastewater. In this research, two key contaminants including COD and hardness were considered to analyze the water network of Tehran oil refinery. Furthermore, regeneration reuse and regeneration recycling processes were placed in the water network assuming that, only 80% of treated wastewater from the regeneration unit may be reused or recycled into operations. The key contaminants once were analyzed separately as a single contaminant and the amount of required fresh water was calculated for each contaminant. The amount of freshwater was reduced about 53% and 63% in terms of COD and H respectively. As a result, water minimization regarding COD was less in comparison with hardness so COD was a limiting contaminant and could be selected as a key contaminant. In the next stage, two mentioned contaminants were analyzed simultaneously based on their mass transfer and the amount of fresh water was reduced about 42%. Clearly, water minimization through single contaminant approach was more considerable. However, results based on double contaminant approach are more precise than single one. It is suggested that more contaminants are considered for study of water networks and reach water utility optimization based on key contaminant as well. Besides, mathematical optimization methods and computer programming could be used to obtain results that are more exact.

REFERENCES

Abduli, M. A., Nabi Bidhendi, G. R., Nasrabadi, T. and Hoveidi, H. (2007). Evaluating the Reduction of Hazardous Waste Contact in Tabriz Petrochemical Complex, Focusing on Personal Protective Equipment Method. *Int. Journal. Environ. Res.*, 1 (1), 14-18.

Ahmed, T. A. and Al-Hajri, H. H. (2009). Effects of Treated Municipal Wastewater and Sea Water Irrigation on Soil and Plant Characteristics. *Int. J. Environ. Res.*, 3 (4), 503-510.

Alizadeh, E. and Pishgahi Fard, Z. (2010). The Position of Environmental Threats in Creating Different Models of Regional Integration. *Int. J. Environ. Res.*, 4 (3), 541-548.

Alva-Argaez, A., Kokossis, A.C. and Smith, R. (2007). The design of water-using systems in petroleum refining using a water-pinch decomposition. *Chemical Engineering Journal*, 128 (1), 33-46.

Amini, H. R., Saeedi, M. and Baghvand, A. (2008). Solidification/Stabilization of Heavy Metals from Air Heater Washing Wastewater Treatment in Thermal Power Plants. *Int. Journal. Environ. Res.*, 2 (3), 297-306.

Aminzadeh, B., Torabian, A., Azimi, A. A., Nabi Bidhendi, Gh. R. and Mehrdadi, N. (2010). Salt Inhibition Effects on Simultaneous Heterotrophic/Autotrophic Denitrification of High Nitrate Wastewater. *Int. Journal. Environ. Res.*, 4 (2), 255-262.

Ataei, A., Panjeshahi, M. H., Gharaie, M., and Tahouni, N. (2009). New Method for Designing an Optimum Distributed Cooling System for Effluent Thermal treatment. *Int. J. Environ. Res.*, 3 (2), 155-166.

Ataei, A., Panjeshahi, M. H. & Gharaie, M. (2009). New Method for Industrial Water Reuse and Energy Minimization. *Int. J. Environ. Res.*, 3 (2), 289-300.

Ataei, A. and Yoo, C. K. (2010). Simultaneous Energy and Water Optimization in Multiple-Contaminant Systems with Flowrate Changes Consideration. *Int. Journal. Environ. Res.*, 4 (1), 11-26.

Bagherzadeh-Namazi, A., Shojaosadati, S. A. and Hashemi-Najafabadi, S. (2008). Biodegradation of Used Engine Oil Using Mixed and Isolated Cultures. *Int. Journal. Environ. Res.*, 2 (4), 431-440.

Bhatnagar, A. and Sangwan, P. (2009). Impact of Mass Bathing on Water Quality. *Int. J. Environ. Res.*, 3 (2), 247-252.

Biati, A., Moattar, F., Karbassi, A.R. and Hassani, A.H. (2010). Role of Saline Water in Removal of Heavy Elements from Industrial Wastewaters. *Int. Journal. Environ. Res.*, 4 (1), 177-182.

Dabhade, M. A., Saidutta, M. B. and Murthy, D. V. R. (2009). Adsorption of Phenol on Granular Activated Carbon from Nutrient Medium: Equilibrium and kinetic Study. *Int. J. Environ. Res.*, 3 (4), 545-556.

El-Halwagi, M. & Srinivas, B. K., (1992). Synthesis of reactive mass-exchange networks. *Chem. Eng. Sci.*, 47 (8), 2113-2119.

Foo, D. C., Manan, Z. A. and Tan, Y. L. (2005). Synthesis of maximum water recovery network for batch process systems. *J. Cleaner Production*, 13(15), 1381-1394.

Gouws, J.F., Majoji, T. and Gadalla, M., (2008). Flexible mass transfer model for water minimization in batch plants. *Chem. Eng. & Process.: Process Intensification*, 47 (12), 2323-2335.

Gomez, E. M. Queiroz, F. and Pessoa L. P. (2006). Design procedure for water/wastewater minimization: Single contaminant. *J. Cleaner Production*, 15 (5), 474-485.

Hallale, N., (2002). A new graphical targeting method for water minimization. *Advances in Env. Res.*, 6 (3), 377-390.

- Hassani, A. H., Otadi, N., Javid, A. H., Khiabani, F. F. and Hoshyaripour, G. (2009). Improving the performance of Pars Oil Refinery Wastewater Treatment System. *Int. Journal. Environ. Res.*, **3 (4)**, 653-662.
- Hassani, A. H., Seif, S., Javid A. H. and Borghei, M. (2008). Comparison of Adsorption Process by GAC with Novel Formulation of Coagulation – Flocculation for Color Removal of Textile Wastewater. *Int. Journal. Environ. Res.*, **2 (3)**, 239-248.
- Kabir, G. and Ogbeide, S. E. (2008). Removal of Chromate in Trace Concentration Using Ion Exchange From Tannery Wastewater. *Int. Journal. Environ. Res.*, **2 (4)**, 377-384.
- Karbassi, A. R., Abduli, M. A. and Neshastehriz, S. (2008). Energy Saving in Tehran International Flower Exhibition's Building. *Int. J. Environ. Res.*, **2 (1)**, 75-86.
- Khezri, S. M., Lotfi, F., Tabibian, S. and Erfani, Z. (2010). Application of water pinch technology for water and wastewater minimization in aluminum anodizing industries. *Int. Journal. Environ. Sci. Tech.*, **7 (2)**, 281-290.
- Kuo, K. and Smith, R. (1997). Effluent treatment system design, *Chem. Eng. Sci.*, **23**, 4273-4290.
- Majozi, T. (2005). An effective technique for wastewater minimization in batch processes. *J. Cleaner Production*, **13 (15)**, 1374-1380.
- Mann, G. and Liu, Y. A. (1999). Industrial water reuse and wastewater minimization. McGraw Hill.
- Manan, Z.A., Wan Alwi, S.R. and Ujang, Z. (2006). Water pinch analysis for an urban system: a case study on the Sultan Ismail Mosque at the University Technology Malaysia (UTM). *Desalination*, **194**, 52-68.
- Mehrdadi, N., Joshi, S. G., Nasrabadi, T. and Hoveidi, H. (2007). Application of Solar Energy for Drying of Sludge from Pharmaceutical Industrial Waste Water and Probable Reuse. *Int. Journal. Environ. Res.*, **1 (1)**, 42-48.
- Moayed Salehi M. and Mirbagheri, S. A. (2010). Determination of Kinetic Constants and Biological Treatment of Automobile Industries Wastewater. *Int. Journal. Environ. Res.*, **4 (1)**, 131-136.
- Mohammadnejad, S., Nabi Bidhendi, G. R. and Mehrdadi, N. (2010). A New Algorithm for Water and Wastewater Optimization in Multiple Contaminants Network using Water Pinch Technology. *Res. J. Environ. Sci.*, **4 (3)**, 193-208.
- Nabi Bidhendi, Gh. R., Torabian, A., Ehsani, H., Razmkhah, N. and Abbasi, M. (2007). Evaluation of Industrial Dyeing Wastewater Treatment with Coagulants. *Int. Journal. Environ. Res.*, **1 (3)**, 242-247.
- Najafpour, Sh., Alkarkhi, A. F. M., Kadir, M. O. A. and Najafpour, Gh. D. (2008). Evaluation of Spatial and Temporal Variation in River Water Quality. *Int. J. Environ. Res.*, **2 (4)**, 349-358.
- Nakane, K. and Haidary, A. (2010). Sensitivity Analysis of Stream Water Quality and Land Cover Linkage Models Using Monte Carlo Method. *Int. J. Environ. Res.*, **4 (1)**, 121-130.
- Oliver, P., Rodriguez, R. and Udaquiola, S. (2008). Water use optimization in batch process industries. Part 1: design of the water network. *J. Cleaner Production*, **16 (12)**, 1275-1286.
- Omran, A., Mahmood, A. and Abdul Aziz, H. (2009). New Method for Industrial Water Reuse and Energy Minimization. *Int. Journal. Environ. Res.*, **3 (2)**, 289-300.
- Praveena, S. M., Abdullah, M. H. and Aris, A. Z. (2010). Modeling for Equitable Groundwater Management. *Int. J. Environ. Res.*, **4 (3)**, 415-426.
- Rajakumar, R. and Meenambal, T. (2008). Comparative Study on Start - Up Performance of HUASB and AF Reactors Treating Poultry Slaughterhouse Wastewater. *Int. Journal. Environ. Res.*, **2 (4)**, 401-410.
- Rajasimman, M. and Karthikeyan, C. (2009). Optimization studies in an Inverse Fluidized Bed Bioreactor for Starch Wastewater Treatment. *Int. Journal. Environ. Res.*, **3 (4)**, 569-574.
- Saeedi, M. and Amini, H. R. (2007). Chemical, Physical, Mineralogical, Morphology and Leaching Characteristics of a Thermal Power Plant Air Heater Washing Waste. *Int. Journal. Environ. Res.*, **1 (1)**, 74-79.
- Salehi, F., Monavari, S. M., Arjomandi, R., Dabiri, F. and Samadi, R. (2010). A New Approach Towards Environmental Monitoring Plan in Steam Power Plants. *Int. J. Environ. Res.*, **4 (3)**, 433-438.
- Sarparastzadeh, H., Saeedi, M., Naeimpoor, F. and Aminzadeh, B. (2007). Pretreatment of Municipal Wastewater by Enhanced Chemical Coagulation. *Int. Journal. Environ. Res.*, **1 (2)**, 104-113.
- Vargas-Vargas, M., Meseguer-Santamaría, M. L., Mondéjar - Jiménez, J. and Mondéjar Jiménez, J. A. (2010). Environmental Protection Expenditure for Companies: A Spanish Regional Analysis. *Int. J. Environ. Res.*, **4 (3)**, 373-378.
- Wang, Y. P. and Smith, R. (1994). Wastewater minimization. *Chem. Eng. Sci.*, **49**, 981-1006.
- Yoochatchaval, W., Ohashi, A., Harada, H., Yamaguchi, T. and Syutsubo, K. (2008). Intermittent Effluent Recirculation for the Efficient Treatment of Low Strength Wastewater by an EGSB Reactor. *Int. Journal. Environ. Res.*, **2 (3)**, 231-238.