

---

# PET

\*

- -  
- -

-  
( // , // , // )

UV

SU8 PMMA

X

LIGA

(SU8)

(MEMS)

X

UV

LIGA

.[ - ]

---

LIGA

PET

[ - ]

( - )

PET

[ - ]

PET

RCA#1

( ) - ( )  
( )

DI

(DCM)

X

( - )

DMF

---

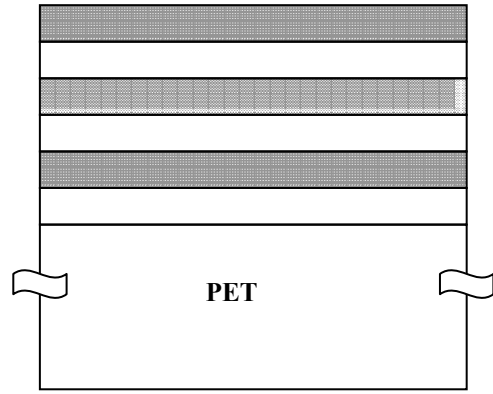

( )

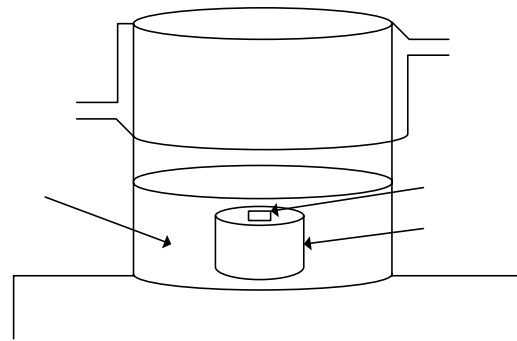

( )

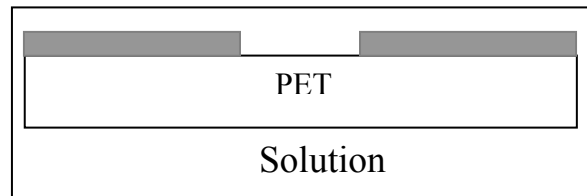
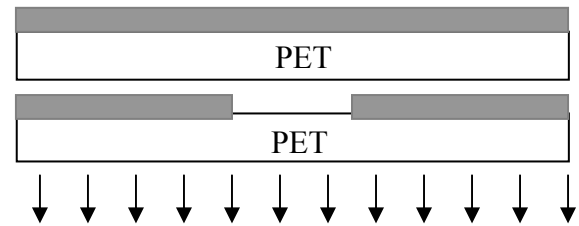
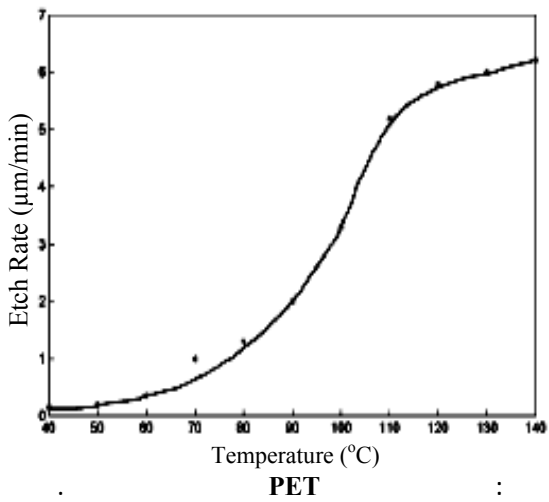

( )

( ):

( )

( )

( ).

( - )

UV

$\text{mW}/\text{cm}^2$

UV

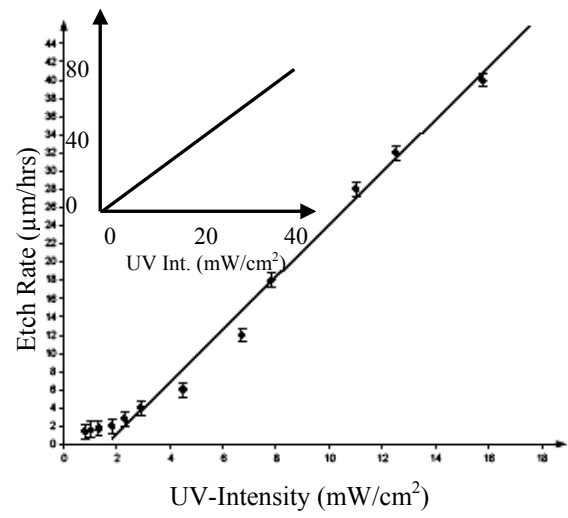
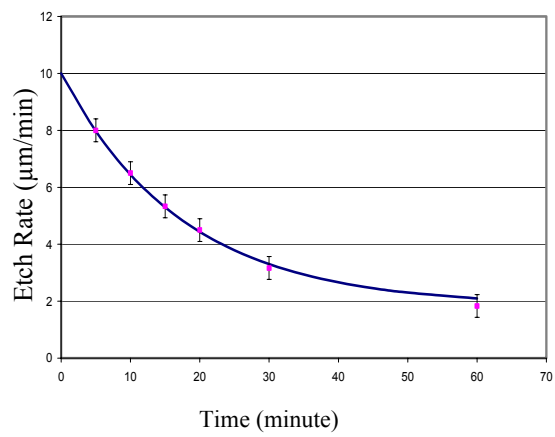

.PET

UV

( )

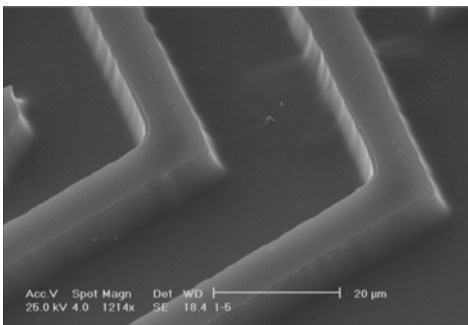

( )

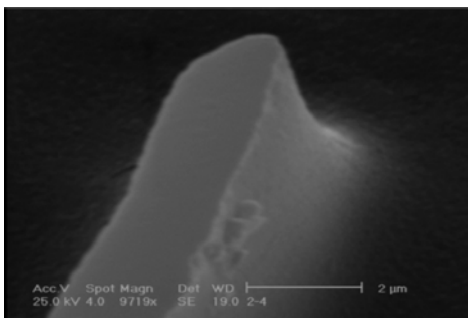

( )

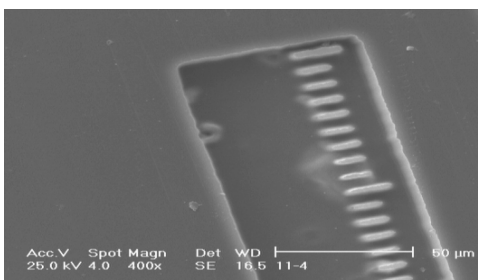

( )



( )

( )

( )

( )

( )

( )

$$R(t) = (R_0 - R_\infty) \exp(-t/\tau) + R_\infty$$

"t" R(t)  
τ R∞ R0

/ R∞ R0

/

( ) ( )

( - )

(under-cut)

( )

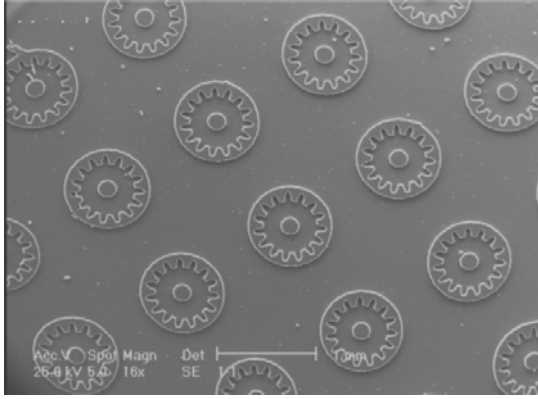

( )  
( )

( )

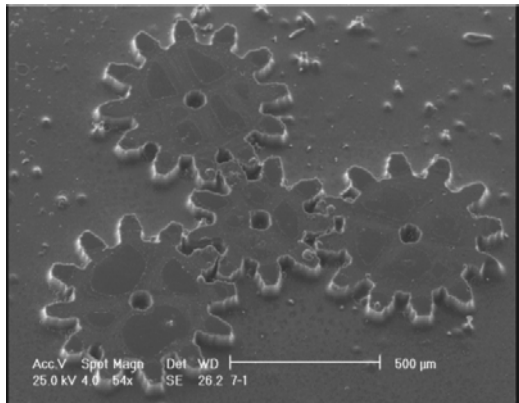

( - )

)

(

( )

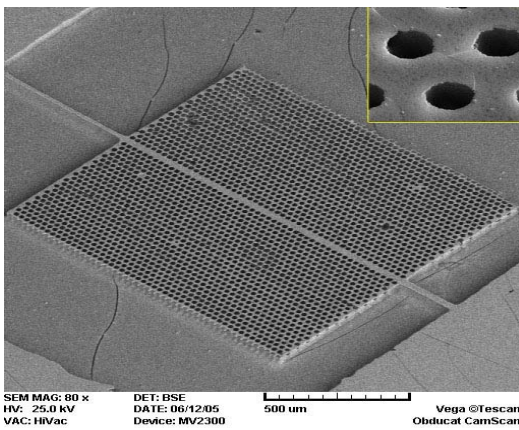

( - )

(Dek-Tak 3B)

( )

( ):

( )

( ) ( )

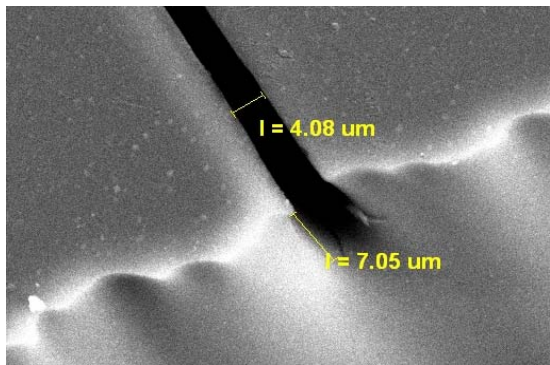

( )

( )

( ) .PET

( )

( - )

( )

( )

( )

( )

( )

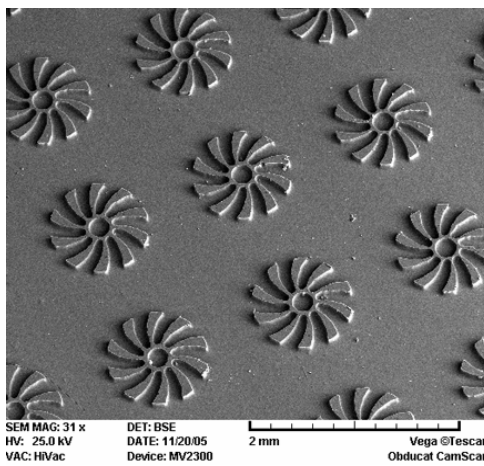

( )

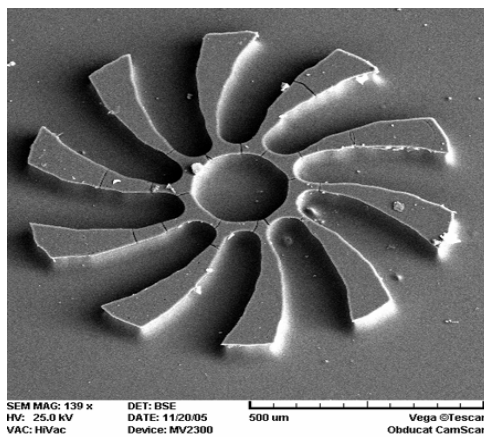

( )

( - )

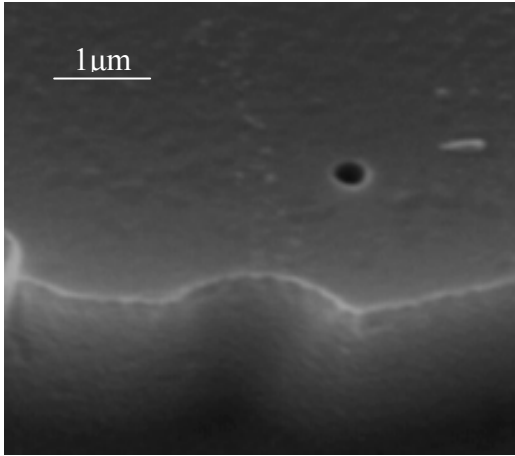

( )

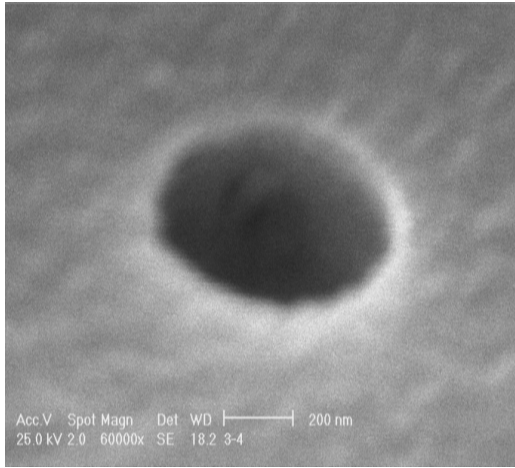

( )

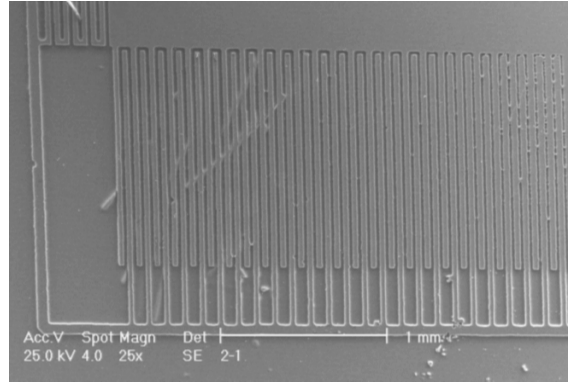

( )

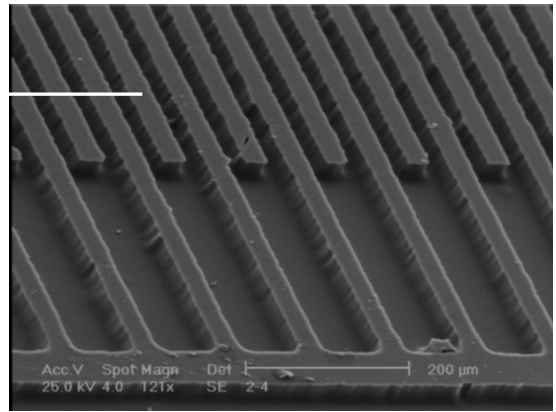

( )

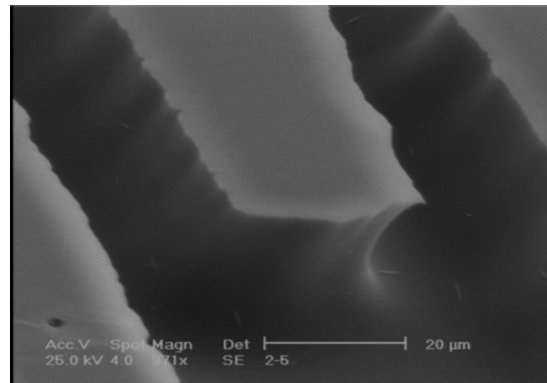

( )

**(inter-digital)**

( )

( - )

( )

( - )

( )

( )



)

(

PET

UV

- 1 - Alavi, M., Schumacher, A. and Wagner, H. J. (1991). "Laser machining and anisotropic etching of <111> silicon for applications in Microsystems." *In Proc. Micro Syst. Technol.*, PP. 227–231.
  - 2 - Wensink, H., de Boer, M. J., Wiegerink, R. J., Zwijze, R. A. F. and Elwenspoek, M. C. (1998). "First micromachined silicon load cell for loads up to 1000 kg." *Proc. SPIE, Micromach. Devices Comp. IV*, Vol. 3514, PP. 424–430.
  - 3 - Berenschot, J. W., Oosterbroek, R. E., Lammerink, T. S. J. and El-wenspoek, M. C. (1998). "Micromachining of <111> plates in <001> oriented silicon." *J. Micromech. Microeng.*, Vol. 8, PP. 104–107.
  - 4 - Gui-Zhen Yan; Chan, P.C.H.; I-Ming Hsing; Sharma, R.K.; Sin, J.K.O. (2000). "An improved TMAH Si-etching solution without attacking exposed aluminum." *Micro Electro Mechanical Systems, 2000. MEMS 2000. The Thirteenth Annual International Conference on 23-27 Jan.* P(s).562 – 567.
-

- 
- 5 - Cristea, D., Purica, M., Manea, E. and Avramescu, V. (2002). "Experiments for micro-photonics components fabrication using Si<111> etching techniques." *Sensors and Actuators A* 99, PP. 92-97.
  - 6 - Cristea, D., Muller, R., Arguel, P., Kusko, M., Tibeica, C. and Syvridis, D. "Micromachined tunable optical microfilters design and experimental processing." (2004). *Proceedings of SPIE, the International Society for Optical Engineering*, v 5455, MEM, MOEMS, and Micromachining, PP. 252-263.
  - 7 - Sammak, A., Azimi, S., Khadem-Hoseini, B., Izadi, N. and Mohajerzadeh, S. (2007). "Deep vertical etching of silicon wafers using a hydrogenation assisted reactive ion etching." *Accepted for publication in IEEE Journal of MEMS*.
  - 8 - Dreuth, H. and Hieden, C. (1999). *Thermoplastic structuring of thin polymer films*, *Sensors and Actuators A* 78, PP.198–204.
  - 9 - Roberts, M.A., Rossier, J., Bercier, P. and Girault, H. (1997). "UV laser machined polymer substrates for the development of micro diagnostic systems." *Anal. Chem.* 69, PP. 2035–2042.
  - 10 - Francou, M., Danel, J. S. and Peccoud, L. (1995). "Deep and fast plasma etching for silicon micromachining." *Sensors and Actuators A* 46-47, PP. 17-21.
  - 11 - Rossier, J. S., Vollet, C., Carnal, A., Lager, G., Gobry, V., Girault, H.H., Michel, P., Reymond, F. et al. (2002). *Plasma etched polymers microelectronic systems*, *LAB Chip* 2, PP.145–150.
  - 12 - Maleki, T., Mohajerzadeh, S. and Afzali-Kusha, A. (2003). "Plastic micromachining assisted by ultraviolet illumination." *IEEE Trans. Electron Devices*, Vol. 50, No. 8, PP.1813–1815.
  - 13 - Sadeghi, B., Ghafouri-Fard, M.R., Mohajerzadeh, S., Miri, M., Mohammadi, S. and Asl. Soleimani, E. (2004). "A novel ultra-violet assisted anisotropic etching of plastic to realize micro-gears." *Sensors and Actuators, A*.

- 1 - UV-curable adhesive
  - 2 - Poly-Ethylene Terephthalate
  - 3 - Di-Methyl-Formamide
  - 4 - Di-Chloromethane
-